





-86°C Ultra-low Temperature Freezer

*Targeted Refrigeration • Fast Refrigeration
Energy-saving & Environmentally Friendly
Awarded with the Second Prize under State
Technological Invention Award*



DW-HL100HC



-  **Precise Temperature Control and Safe Storage**
Microprocessor-based temperature controller, -40°C~-86°C can be set freely with display accuracy at 0.1°C.
-  **Visual & Audio Alarm system**
High/low temperature alarm, power failure alarm, low battery alarm, door ajar alarm, high ambient temperature alarm, communication failure alarm etc.
-  **Human-oriented**
The rotating handle facilitates door opening;
The two-door design including the inner door and the outer door can lock cool air inside the cabinet and ensure thermal insulation for along period.
-  **Energy-saving & Environmentally Friendly**
Awarded with China Certificate for Energy Conservation Product, certificate numbers: CQC18702198375;
Awarded with China Certificate for Ecolabelling Products, certificate numbers: CQC18702198376.



High-precision Temperature Control

- Digital temperature display, simultaneously display the chamber temperature, power supply voltage, ambient temperature and other parameters etc. The running status is clearly displayed;
- The high-precision microcomputer temperature control system and platinum resistor temperature sensors enable users to set temperature inside the cabinet within a range from -40°C to -86°C.



Refrigeration System

- The imported high-efficiency compressor and EBM fan are energy-saving and highly efficient;
- The large finned condenser with a space between fins $\leq 2\text{mm}$, providing effective heat dissipation;
- Standard with VIP board for high efficiency cooling performance. Door with hot gas pipe surrounding for defrost.



Supplies for Cryopreservation

Freezer racks/boxes for cryopreservation are optional.

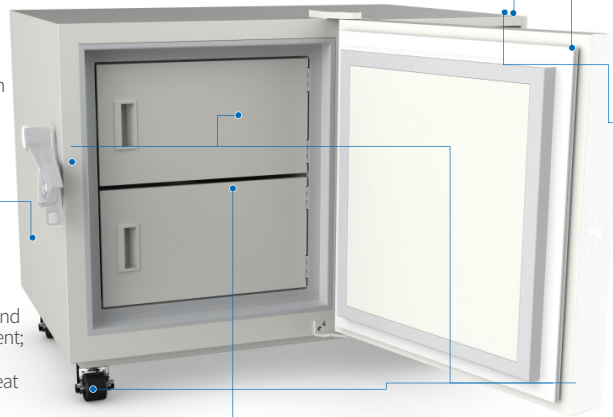

Thermal Insulation System

- The insulated foamed outer door with seal design prevents loss of cooling capacity effectively;
- The six sides of the cabinet are made from high performance vacuum insulation material, greatly improving thermal insulation performance.



Security System

- The perfect audible & visual alarm system: high/low temperature, sensor failure, door ajar, power failure, low battery etc.;
- The turn-on delay and stopping interval protection can ensure reliable operation;
- The keyboard lock and password protection can prevent any adjustment of operation without permission;



Human-oriented

- The door with new-type assisting door handle to be opened easily;
- Door handle with lock for safety operation;
- 304 Stainless steel interior, low temperature resistance anti-corrosion for long service life and easy cleaning;
- Universal wheels easy for movement and fixation.

Scope of Application

Suitable for use in blood banks, hospitals, health and disease prevention systems, research institutions, colleges & universities, the electronic industry, biological engineering, laboratories in colleges & universities, military enterprises, deep-sea fishing companies, etc.

Performance Data / Cooling Curve

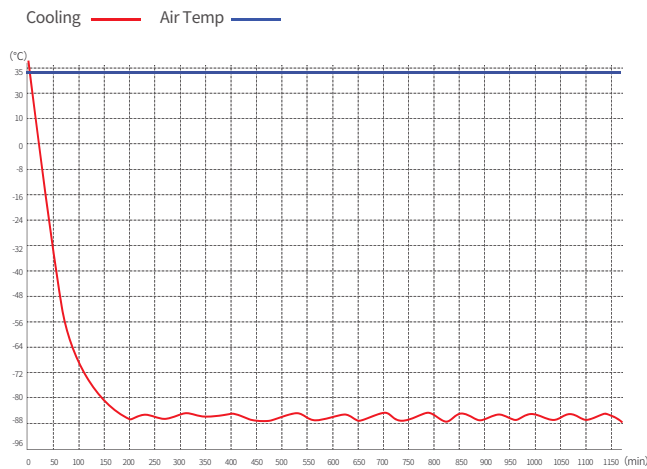

External Dimension

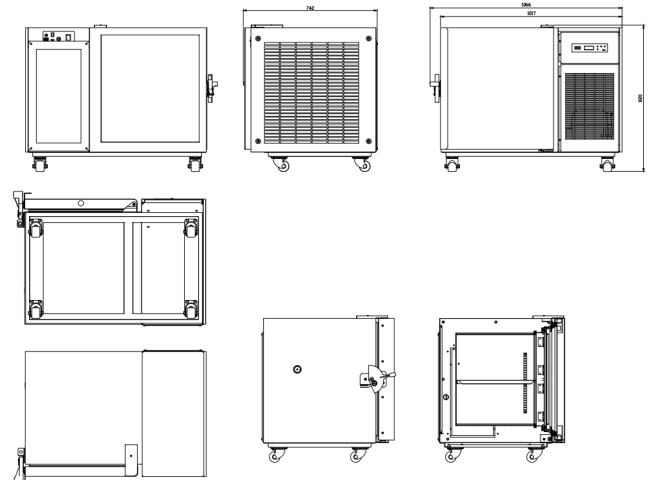

Specification Chart

-86°C Ultra-low Temperature Freezer	
Model	DW-HL100HC
Cabinet Type	Upright
Capacity(L)	100
Internal Size(W*D*H)mm	450*450*514
External Size(W*D*H)mm	1066*742*820
Package Size(W*D*H)mm	1200*863*991
NW/GW(Kgs)	145/189
Performance	
Temperature Range	-40~-86°C
Ambient Temperature	16-32°C
Cooling Performance	-86 °C
Climate Class	N
Controller	Microprocessor
Display	Digital display
Refrigeration	
Compressor	1pc
Cooling Method	Direct cooling
Defrost Mode	Manual
Refrigerant	HC
Insulation Thickness(mm)	L:90,R:115
Construction	
External Material	Cold rolled steel sheet
Inner Material	Stainless steel
Shelves	1(stainless steel)
Door Lock with Key	Yes
Padlock	Yes
Access Port	1pc. Ø 25 mm
Casters	4
Data Logging/Interval/Recording Time	USB/Record every 10 minutes / 2 years
Backup Battery	Yes
Alarm	
Temperature	High/Low temperature,High ambient temperature
Electrical	Power failure , Low battery
System	Sensor failure, Condenser overheating alarm,Door ajar, Built-in USB datalogger failure, Communication error
Electrical	
Power Supply(V/HZ)	220-240~/50
Power(W)	761
Power Consumption(KWh/24h)	8.66
Rated Current(A)	5.57
Accessories	
Standard	RS485, Remote alarm contact
Options	CO ₂ backup system

*The model, parameters and performance specified in this brochure may be changed without prior notice because of product upgrading.

*There may be differences between the product images shown in this brochure and the actual products. When you are buying any product, please check the actual product.