

Counting Scales

GC Series



*Today's counting solutions,
only from A&D.*

A&D
A&D Company, Ltd.

Discover Precision
www.aandd.jp

Because All You Want to Do Is “Count”

If people appear to be counting faster, it may not be that they are better trained. Featuring A&D’s uniquely innovative solutions, the GC series of counting scales let you spend much less time and effort on setup and preparation so that you can start counting right away. The GC series is also designed to be able to connect with various other devices to expand their capabilities as needed, while being extremely functional as well as being affordable enough to be purchased for stand-alone operations.

Multiple displays for different purposes

For maximum efficiency and ease of operation, the scale has three separate reverse-backlit LCD displays for count, weight, and unit weight data, and one OLED*¹ information display.

*¹ Organic light-emitting diode



The count and weight displays can be switched if you prefer that weight data be displayed in the larger character size.

■ Information display also acting as a simplified guide for internal settings

In addition to icons and animations which help you intuitively grasp what operation is currently being performed, it indicates parameter contents as a simplified guide during internal settings so you need not refer to the instruction manual every time.

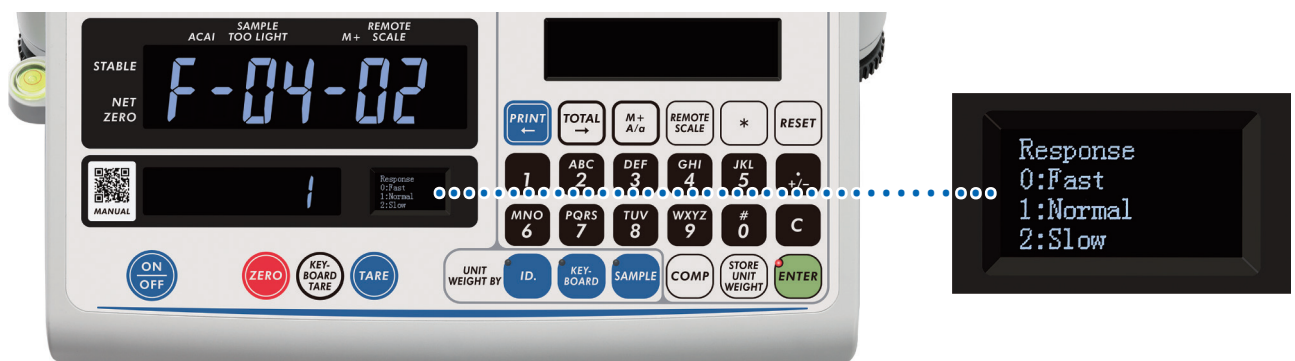

Example of the response speed setting assisted by the OLED information display

Separable display unit

The display unit can be detached from the weighing unit for ergonomic use depending on the device layout. The length of the standard cable that connects the display and weighing units is approx. 1 m. An optional extension cable (GC-08, approx. 2 m) is also available to replace the standard cable.



Display unit detached from the weighing unit

Diverse methods of unit weight setting

You can select one of three ways to set a unit weight (= weight of one piece of the item to be counted) as the situation demands.

Sample Mode

Have the scale calculate the average piece weight from the total weight of a preset or arbitrary number of sample pieces.

Key Mode

Enter a known unit weight value using the numeric keys on the scale or from an external device such as a PC.

Search Mode

Call up the unit weight to use from the internal or external (MicroSD card) memory data.

■ Unit weight entry navigator

No need to worry even if you are an inexperienced user. The scale navigates you through unit weight setting with text and small red LED lamps as it is turned on.



Example of selecting Sample Mode to set a unit weight

Large internal memory to store data for up to 1,000 items

To recall and immediately use at any time, the GC series can store 20-character (max.) item code, tare weight, total count / number of additions and comparator limits, on top of 6-digit ID number and unit weight for as many as 1,000 items.

■ Unit weight backup

The unit weight currently in use is backed up in the internal memory with the ID number 000000 so that it can be retrieved at once even if the scale is accidentally reset or turned off.

Memory capacity extension using a MicroSD card

The GC series also allows for the insertion and reading of a MicroSD card,*2 to which data for a practically infinite number of items can be created and saved in CSV format using a PC. You can either call up the unit weight and other information of a desired item directly from the MicroSD card, or transfer the list file to the internal memory of the scale.*3

- *2 Operation is not guaranteed for all MicroSD cards.
- *3 The first 1,000 items will be copied if the number of items in the list file exceeds 1,000.



Slot for a MicroSD card

Automatic Item Search (AIS)♦ to instantly find a desired unit weight

Individual item data can be easily called up from the vast list in the internal or external (MicroSD card) memory by entering an ID number or item code (the scale performs a case-sensitive prefix search when searching for an item code). ♦ Patent pending

Furthermore, when the Automatic Item Search (AIS) function is used, the scale will automatically find and set an item (unit weight) based on the weight detected by the scale.*4 You simply have to place a piece of the item you are counting on the scale, and confirm whether the set item is the one you are looking for (or change to next match*5 if it is not) so that counting can begin straight away.



Just place a piece of the item you wish to count on the pan.



The scale automatically sets a unit weight based on the weight on the pan.

Not only can this function save the hassle of having to enter an ID number / item code, but it can also be extremely helpful in case you have difficulty remembering the ID number / item code for the pieces at hand.

- *4 Effective only when the unit weight is outside the near-zero range (± 4 scale divisions in kg).
- *5 For the internal memory, ten closest unit weights within approx. $\pm 5\%$ of the weight on the scale are suggested in approximate order. For the external (MicroSD card) memory, all unit weights within approx. $\pm 5\%$ of the weight on the scale are suggested in order of listing in the file.

Any counting scale can let you perform counting. The GC series also tells you what you are counting.

WinCT-Counting (freeware) for easy management of item data

Consisting of four useful modes, the WinCT-Counting software lets you perform various tasks on a PC to enable more effective and efficient use of the GC series.

UFC Mode

Useful for editing and sending UFC setting commands to a counting scale for customization of printout content and layout.

Function Mode

Useful for checking and configuring internal settings of a counting scale (enabled regardless of whether the scale is password-locked).

WinCT-Counting

Command Mode

Useful for sending commands to and receiving/saving data from a counting scale.

Memory Mode

Useful for reading/opening, creating, editing and saving a list of items and their data in either the internal or external (MicroSD card or PC) memory.

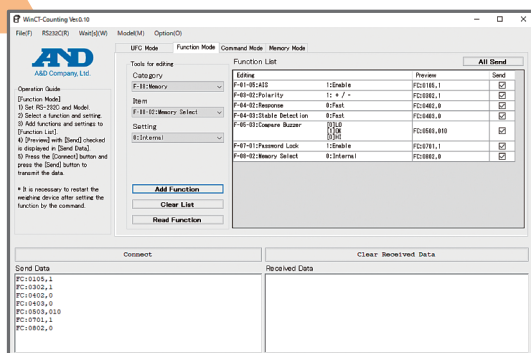

Configuration of internal settings in Function Mode

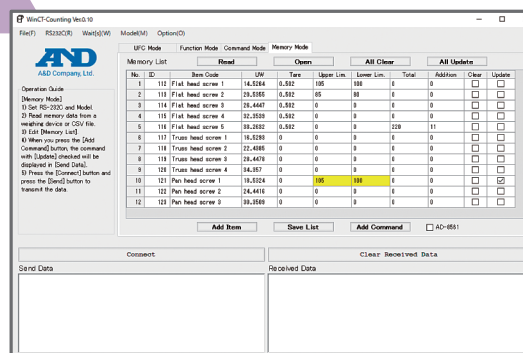

Management of item data in Memory Mode

Selectable power sources including mobile battery via USB cable

The GC series is equipped as standard with a USB connector and cable.*6 It can be connected to either the provided AC adapter, USB port of another device, or off-the-shelf mobile battery.*7 Power supply from a mobile battery is especially convenient if the scale is to be carried and used at different locations.

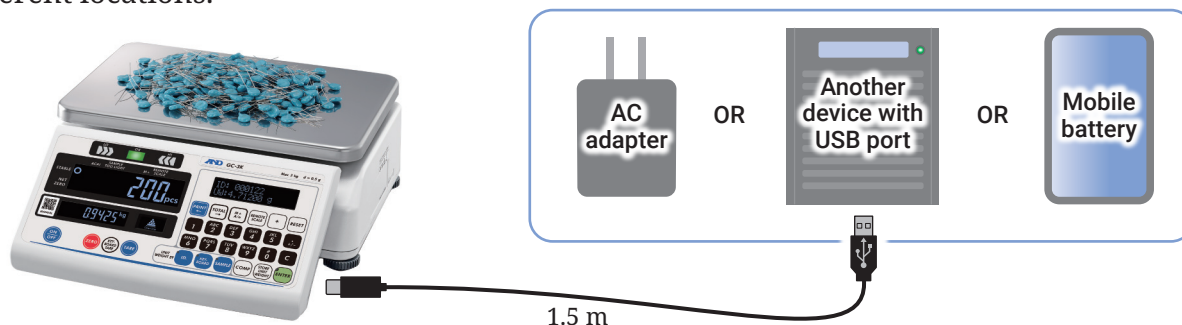

For reference, continuous operation time with an off-the-shelf mobile battery is estimated to be approx. 24 hours for 5,000 mAh and approx. 50 hours for 10,000 mAh with comparator lights off and no other external device connected to the scale.

*6 Type-C on the scale side and Type-A on the other side. Data communication is not supported.

*7 Operation is not guaranteed with other AC adapters, USB ports of all devices, or all mobile batteries.

RS-232C interface that supports digital connection with an A&D balance/scale

The GC series is also equipped as standard with an RS-232C (D-Sub 9-pin) interface so that bi-directional serial communication (i.e. sending data and receiving commands) with an external device such as a printer or PLC can be made. Moreover, an A&D balance/scale can also be connected via the RS-232C interface,*8 which allows a high-precision balance to be used to set a minute unit weight, or a large-capacity/platform scale to be used to count the target item of a large quantity.



Example of connecting an A&D analytical balance (GX-324AE) to the GC series

*8 A crossover RS-232C cable is required (AX-KO1371-200 is available from A&D). The RS-232C (D-Sub 9-pin) interface of the AD-8561 series described below cannot be used for this purpose.

Expanded scope of application using the AD-8561 series of Multi-Interfaces (sold separately)

With one of the following Multi-Interface options (connected to the RS-232C interface of the scale), multiple different devices can be used with the GC series. All of these options have one RS-232C (D-Sub 9-pin) interface and one USB (Type-A) interface, in addition to one interface specific to each model, as shown in the table below.



Model	Equipped with	Intended for	
AD-8561	Common	RS-232C (D-sub 9-pin) × 1 USB (Type-A) × 1	Printer/PC (bi-directional) Barcode scanner/keyboard input
	-MI02	USB (Type-micro B) × 1	PC (bi-directional)
	-MI04	Terminal (4-pin) block × 1	Comparator relay output
	-MI05	Terminal (7-pin) block × 1	External scale (load cell) input



How the AD-8561-MI02 can be used to connect a barcode scanner, printer, and PC to the GC series

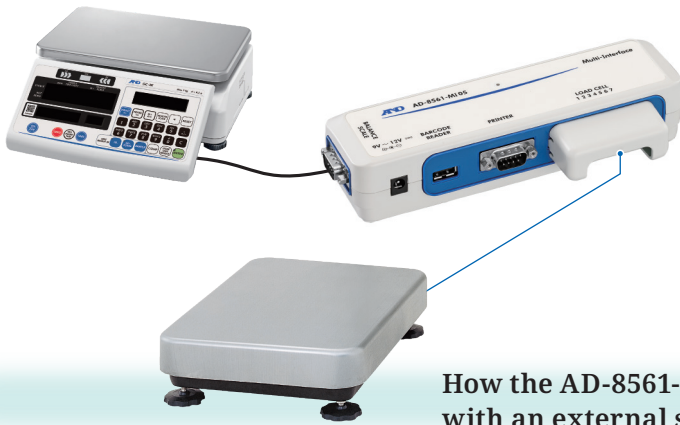

Model	Capacity	Size
SB-15K10	15 kg	250 × 250 mm
SB-60K11	60 kg	330 × 424 mm
SB-100K12	100 kg	390 × 530 mm
SB-200K12	220 kg	
FW-300KB4	300 kg	700 × 600 mm
FW-600KB4	600 kg	
FW-600KB3		
FW-1200KB3	1200 kg	1000 × 1000 mm

External scales available from A&D

How the AD-8561-MI05 can be used for analog connection with an external scale (load cell)

If you prefer not to leave the connected Multi-Interface and cable loose, optional brackets (GC-14) can fasten them securely to the scale.



The AD-8561-MI02 and cable fastened to the scale by the GC-14

Discover increase in value through connectivity and augmentation with various other devices.

Other useful features

- ✓ Comparator function with highly-visible LED traffic lights and buzzer for intuitive, error-free check counting/weighing
- ✓ Automatic Counting Accuracy Improvement (ACAI), which automatically optimizes the accuracy of the unit weight while counting
- ✓ Accumulation (M+) function to determine the total count and the number of additions (i.e. counts performed) from separate counting results
- ✓ Stabilization of approx. 1 second (typical)*9 for high-speed counting/weighing
- ✓ Universal Flexi Coms (UFC), by which you can customize printout content and layout for barcode label printing as well as dump printing
- ✓ Password lock function to prevent operators from making unauthorized changes to the scale settings
- ✓ Key lock function that helps avoid unnecessary/incorrect operations of the scale as well as accidental changes to or deletion of stored data
- ✓ External input terminal that allows up to two commands to be entered using an external switch or other device*10



LED traffic lights

*9 By default settings, the stabilization time is approx. 1.6 seconds.
 *10 A 3.5 mm stereo plug (NYS231B from REAN or equivalent) is required.

Specifications

	GC-3K	GC-6K	GC-15K	GC-30K
Capacity	3 kg	6 kg	15 kg	30 kg
Readability	0.0005 kg	0.001 kg	0.002 kg	0.005 kg
Units of measure	kg (kilogram), g (gram), lb (pound), oz (ounce), ozt (troy ounce), and pcs (pieces)			
Number of samples	5, 10, 25, 50, 100, or an arbitrary number of pieces			
Minimum unit weight* ⁱ	0.1 g / 0.005 g	0.2 g / 0.01 g	0.4 g / 0.02 g	1 g / 0.05 g
Repeatability (std. deviation)	0.0005 kg	0.001 kg	0.002 kg	0.005 kg
Linearity	±0.0005 kg	±0.001 kg	±0.002 kg	±0.005 kg
Stabilization time	Approx. 1 sec.* ⁱⁱ			
Sensitivity drift	±20 ppm / °C (5 to 35 °C / 41 to 95 °F)			
Operating environment	0 °C to 40 °C / 32 °F to 104 °F, 85% R.H. or less (no condensation)			
Display	Count	7-segment reverse-backlit LCD (character height: 22 mm)		
	Weight	7-segment reverse-backlit LCD (character height: 12.5 mm)		
	Unit weight	5 × 7 dot reverse-backlit LCD (character height: 6.7 mm)		
	Information	128 × 64 dot OLED		
Display refresh rate	Approx. 10 times / second (for the count and weight displays)			
Standard interface	RS-232C (D-Sub 9-pin), MicroSD card* ⁱⁱⁱ slot, External input terminal			
Power supply	AC adapter (provided as standard), USB port of another device, or off-the-shelf mobile battery* ^{iv} via USB cable (Type-A to Type-C, 1.5 m)			
Weighing pan size	300 × 210 mm / 11.81 × 8.27 in			
Dimensions (W × D × H)	315 × 355 × 121 mm / 12.4 × 13.98 × 4.76 in			
Weight (approx.)	4.9 kg / 10.8 lb			
Materials	Display unit: ABS + polyester film, Base unit: Die cast aluminum + ABS, Weighing pan: SUS430			

*ⁱ Selectable by internal setting

*ⁱⁱ Typical value when the response characteristics and stability detection conditions are both set to prioritize speed.

*ⁱⁱⁱ Card type: SDHC. File system: FAT32. Operation is not guaranteed for all MicroSD cards (A&D verified operation with Panasonic's RP-SMGA04GJK 4GB).

*^{iv} Operation is not guaranteed with other AC adapters, USB ports of all devices, or all mobile batteries.

Options

- GC-08 Extension cable (2 m)
GC-14 Brackets for AD-8561 and cable

Accessories

- AD-8561-MI02 Multi-Interface incl. USB (Type-micro B)
AD-8561-MI04 Multi-Interface incl. Terminal (4-pin) block
AD-8561-MI05 Multi-Interface incl. Terminal (7-pin) block
AD-8561-11 Terminal block cover*^v
AX-KO1371-200 Crossover RS-232C cable (2 m)
AX-KO7215-150 USB cable for power supply (1.5 m)*^{vi}

*^v Provided as standard for the AD-8561-MI05 and can also be used for the AD-8561-MI04

*^{vi} Provided as standard for the GC series

Dimensions (mm/inches)

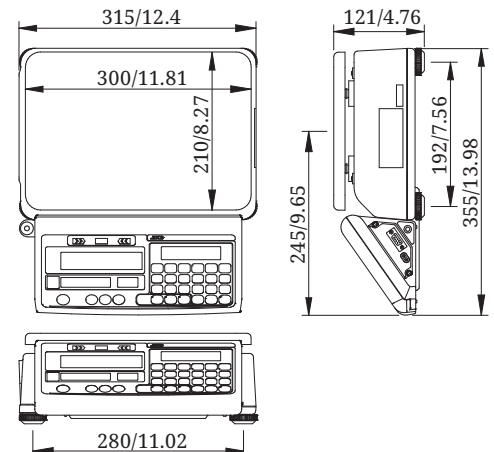

Reverse Backlit LCD + OLED



RS-232C Interface



User Access Control



Data Memory Function



Counting with ACAL



Accumulation Function



Comparator Function



Auto Power ON



Auto Power OFF



Universal Flexi Coms

Optional



Bi-directional USB



Rechargeable Battery*^{vii}

*^{vii} Commercially-available mobile battery



HELAGO-CZ, s.r.o.
Kladská 1082/67
500 03 Hradec Králové
Česká republika

www.helago-cz.cz

Discover Precision

A&D Company, Ltd. (JAPAN)
URL: aand.jp

A&D Engineering, Inc. (USA)
URL: andonline.com

A&D Australasia Pty Ltd. (Australia)
URL: andaustralasia.com.au

A&D Instruments Ltd. (United Kingdom)
URL: andprecision.com

<German Sales Office>
URL: andprecision.com

A&D Korea Ltd. (South Korea)
URL: andk.co.kr

A&D Rus Co., Ltd. (Russia)
URL: and-rus.ru

A&D Instruments India (P) Ltd. (India)
URL: aandindia.in

A&D Sciencetech Taiwan Ltd. (Taiwan)
URL: aandd.com.tw

A&D Instruments Thailand Ltd. (Thailand)
URL: thai.andprecision.com