

Model KBF-S 720 | Constant climate chambers with large temperature / humidity range

The new Solid.Line KBF-S climate chamber is a custom-made solution for long-term testing and accelerated stability testing for pharmaceutical products in accordance with the ICH Q1A guideline. The corrosion-free and condensation-free interior also ensures exceptionally stable temperature and moisture levels, even when fully loaded.

BENEFITS

- Homogeneous climate conditions thanks to APT.line™ preheating chamber
- Standard-compliant testing according to ICH Q1A
- Precise temperature and humidity control



Model KBF-S 720

MAIN FEATURES

- Temperature range: 0 °C to 70 °C
- Humidity range: 20% to 80% RH
- APT.line™ preheating chamber technology
- Humidity regulation with capacitive humidity sensor and steam humidification
- LCD to display temperature and humidity along with additional information and alarms
- Internal data logger, measured values can be read out in open format via USB
- Unit self-test for comprehensive status analysis
- Inner chamber made completely of stainless steel
- 2 stainless steel racks, incl. shelf supports
- Access port with silicone plug, 30 mm, left
- Robust twin casters with brakes, from 240 L
- Class 3.1 independent temperature safety device (DIN 12880) with visual and audible temperature alarm
- Computer interface: Ethernet
- Independent water supply via tank

ORDERING INFORMATION

Interior volume [L]	Voltage	Option model	Version	Art.-No.
700	200...230 V 1~ ph 50/60 Hz	Standard	KBFS720-230V	9020-0368
	200...240 V 1~ ph 50/60 Hz	Standard	KBFS720UL-240V	9020-0369

TECHNICAL DATA

Description	KBFS720-230V ¹	KBFS720UL-240V ¹
Article Number	9020-0368	9020-0369
Performance Data Temperature		
Temperature range	0...70	0...70
Temperature variation at 40 °C [± K]	0.3	0.3
Temperature fluctuation [± K]	0.1	0.1
Max. heat compensation at 40 °C [W]	550	550
Performance Data Climate		
Temperature range [°C]	10...70	10...70
Temperature variation at 25 °C and 60 % RH [± K]	0.3	0.3
Temperature variation at 40 °C and 75 % RH [± K]	0.3	0.3
Temperature fluctuation at 25 °C and 60 % RH [± K]	0.1	0.1
Temperature fluctuation at 40 °C and 75 % RH [± K]	0.1	0.1
Humidity range [% RH]	20...80	20...80
Humidity fluctuation at 25 °C and 60 % RH	1,5 % RH	1,5 % RH
Humidity recovery time after 30 s door open at 25 °C and 60 % RH [min]	16	16
Humidity recovery time after 30 s door open at 40 °C and 75 % RH [min]	17	17
Electrical data		
Rated Voltage [V]	200...230	200...240
Power frequency [Hz]	50/60	50/60
Nominal power [kW]	2.0	2.0
Unit fuse [A]	16	16
Phase (Nominal voltage)	1~	1~
Measures		
Interior volume [L]	700	700
Net weight of the unit (empty) [kg]	284	284
Permitted load [kg]	150	150
Load per rack [kg]	45	45
Wall clearance back [mm]	100	100
Wall clearance sidewise [mm]	300	300
Internal Dimensions		
Width [mm]	973	973
Height [mm]	1250	1250
Depth [mm]	576	576
Doors		
Unit doors	2	2
Housing dimensions not incl. fittings and connections		
Width net [mm]	1250	1250
Height net [mm]	1925	1925
Depth net [mm]	890	890
Environment-specific data		
Energy consumption at 40 °C and 75 % RH [Wh/h]	500	500
Sound-pressure level [dB(A)]	53	53
Fixtures		
Number of shelves (std./max.)	2/15	2/15

1 All technical data is specified for unloaded units with standard equipment at an ambient temperature of +22 °C ±3 °C and a power supply voltage fluctuation of ±10 %. The temperature data is determined in accordance to BINDER factory standard following DIN 12880, observing the recommended wall clearances of 10 % of the height, width, and depth of the inner chamber. Technical data refers to 100 % fan speed. All indications are average values, typical for units produced in series. We reserve the right to change technical specifications at any time.

DIMENSIONS incl. fittings and connections [mm]

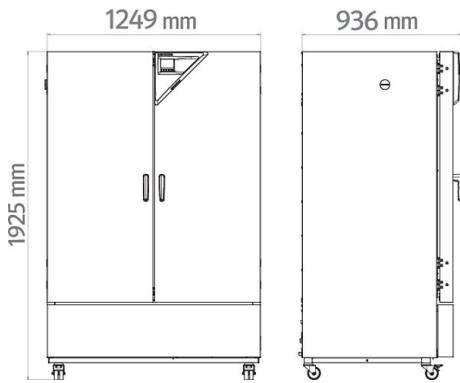

CHARTS

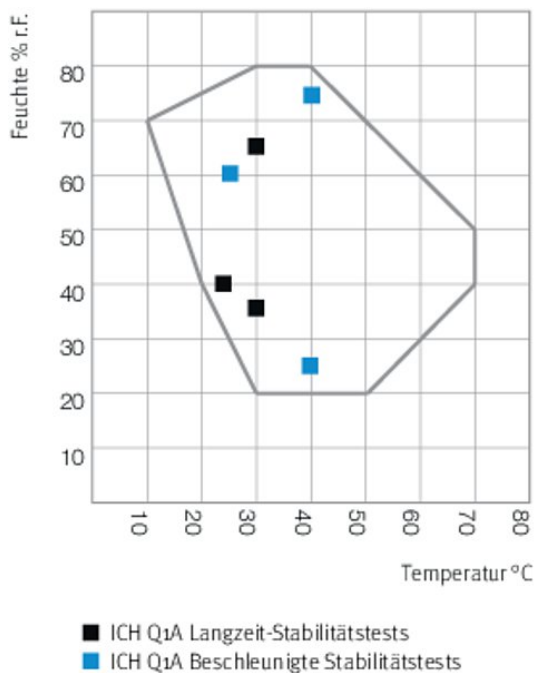

Climate chart

OPTIONS

Designation	Description	*	Art.-No.
	left		
	30 mm	01	8012-1442
	50 mm	01	8012-1472
	100 mm	01	8012-0515
	right		
Access port with silicone plug	30 mm	01	8012-1436
	50 mm	01	8012-1466
	100 mm	01	8012-0514
	top		
	30 mm	01	8012-1448
	50 mm	01	8012-1454
	100 mm	01	8012-1460
Calibration certificate, expanded	for temperature and humidity; for extending the measurement in center of chamber to include another test value	-	8012-0155

* Notes > See last page

Designation	Description	*	Art.-No.
Calibration certificate, temperature	temperature measurement incl. certificate and 27 measuring points at specified temperature	-	8012-0923
	temperature measurement incl. certificate, 15- 18 measuring points at specified temperature	-	8012-0920
	temperature measurement incl. certificate, 9 measuring points at specified temperature	-	8012-0917
Calibration certificate, temperature and humidity	Measurement in center of chamber at 25 °C / 60% RH or at specified test values	-	8012-0154
	temperature (according to DIN12880) and humidity measurement incl. certificate, 27 temperature measuring points and 1 humidity measuring point, at 25 °C / 60 % RH or at specified values	-	8012-0924
Interior socket	Waterproof, switched flush-mounting box (CA3GD) for nominal voltage in unit interior, with cover and corresponding plug (nominal voltage; max. 500 W; max. 90 °C; protection class IP67)	07	8012-1043

* Notes › See last page

ACCESSORIES

Designation	Description	*	Art.-No.
APT-COM™ 4 BASIC-Edition	for simple logging and documentation requirements with up to 5 networked units. version 4, BASIC edition	19	9053-0039
APT-COM™ 4 GLP-Edition	for working under GLP-compliant conditions. Measured values are documented in a tamper-proof way in line with the requirements of FDA Regulation 21 CFR 11. version 4, GLP edition	19	9053-0042
APT-COM™ 4 PROFESSIONAL-Edition	convenient unit and user management built on the BASIC edition. Suitable for networking up to 100 units. version 4, PROFESSIONAL edition	19	9053-0040
BINDER PURE AQUA SERVICE	System for preparation or complete desalination of tap water, complete set containing PURE AQUA 300 single-use cartridge, measuring device, and all necessary connecting parts	-	8012-0759
BINDER PURE AQUA SERVICE, accessories	Single-use, replacement cartridge for BINDER PURE AQUA System	-	6011-0165
Convenient water supply	Flexible positioning of the water container with magnetic holder, hose adapter for water container with practical quick coupling, and water stop function		
	External, with magnetic holder	-	8012-1847
Data Logger Kit	T 220: For continuous temperature logging from -90 °C to 220 °C. The kit includes 1 data logger, Pt 100 sensor with 2 m extension cable and 1 magnetic fixture for mounting to the BINDER unit	19	8012-0715
	TH 70/70: For continuous temperature and humidity logging from -40 °C to 70 °C / 0% to 100% RH and additional logging of ambient conditions. Kit includes 1 data logger, 2 attachable combined humidity/temperature sensors, 2 m extension cable and 1 fixture for mounting to the BINDER unit	19	8012-0717
	TH 70: For continuous temperature and humidity logging from -40 °C to 70 °C; 0% to 100% RH. Kit includes 1 data logger, Pt 100 sensor with 2 m extension cable, and 1 magnetic fixture for mounting to the BINDER unit	19	8012-0716
Data Logger Software	LOG ANALYZE software kit, configuration and evaluation software for all BINDER Data Logger Kits (incl. USB data cable)	19	8012-0821
LED light bars	Basic set consisting of 2 pieces, attachment material, control unit for max. 4 light strips, 100-240 V, 50/60 Hz		
	Basic set 300, length 30 cm	-	8012-1107
	Basic set 500, length 50 cm	-	8012-1108
	Basic set 900, length 90 cm	-	8012-1109
	Expansion set consisting of 2 pieces, attachment material: clips. For expanding the basic set of light bars		
	Expansion set 300, length 30 cm	-	8012-1716
	Expansion set 500, length 50 cm	-	8012-1717
Expansion set 900, length 90 cm	-	8012-1718	
pH-neutral detergent	concentrated, for gentle remove of residual contaminants; 1 kg	-	1002-0016
Qualification documents	IQ/OQ documents – supporting documents for validation performed by customers, consisting of: IQ/OQ checklists incl. calibration guide and comprehensive unit documentation; parameters: temperature and humidity values		
	Digital in PDF format	-	7057-0002
	Hard copy inside folder	-	7007-0002
	IQ/OQ/PQ documents – supporting documents for validation performed by customers, according to customer requirements, PQ section added to qualification folder IQ/OQ; parameters: temperature and humidity values		
Digital in PDF format	-	7057-0006	
Hard copy inside folder	-	7007-0006	

* Notes › See last page

Designation	Description	*	Art.-No.
Rack	stainless steel	-	6004-0106
Rack accessories	fasteners (1 set of 4) for additional security of racks	-	8012-0620
Rack, reinforced	stainless steel, with fasteners (1 set of 4)	-	8012-0674
Shelf, perforated	Stainless steel	-	8009-0486

* Notes › See last page

SERVICES

Designation	Description	*	Art.-No.
Installation services			
Unit installation	Unpacking and setting up of unit, connecting to existing connections, and checking function	13, 18	DL10-0300
Unit instructions	Unit function instructions for operation and programming of the controller	18	DL10-0700
Preventive maintenance			
Maintenance	Functional testing of all electrical and mechanical components, short calibration, documentation in the maintenance schedule	14, 18	DL20-0400
Calibration services			
Temperature and humidity calibration	Temperature and humidity calibration with 1 measuring point in center of chamber with 1 specified pair of values, including certificate	14, 16, 17, 18	DL30-0301
Temperature measurement in accordance with DIN 12880, 27 temperature measuring points and 1 humidity measuring point	Temperature measurement in accordance with DIN 12880 with 27 temperature measuring points and 1 humidity measuring point in center of chamber at specified values, including certificate	14, 16, 17, 18	DL30-0427
Temperature measurement, 18 temperature measuring points and 1 humidity measuring point	Temperature measurement with 18 temperature measuring points and 1 humidity measuring point in center of chamber with 1 specified pair of values, including certificate	14, 16, 17, 18	DL30-0318
Temperature measurement, 27 temperature measuring points and 1 humidity measuring point	Temperature measurement with 27 temperature measuring points and 1 humidity measuring point in center of chamber with 1 specified pair of values, including certificate	14, 16, 17, 18	DL30-0327
Temperature measurement, 9 temperature measuring points and 1 humidity measuring point	Temperature measurement with 9 temperature measuring points and 1 humidity measuring point in center of chamber at specified values, including certificate	14, 16, 17, 18	DL30-0309
Validation services			
Execution of IQ/OQ	Execution of IQ/OQ in accordance with qualification folder	15, 18	DL42-0300
Execution of IQ/OQ/PQ	Execution of IQ/OQ/PQ in accordance with qualification folder	15, 18	DL44-0500

* Notes › See last page

NOTES

- 01 Condensation may occur in the area around the access port. Access ports may be placed in custom locations for an additional charge.
- 02 UL mark is not granted when this option is used.
- 03 Heat resistant only to max. 200 °C.
- 04 Only available on units rated for 230 V.
- 07 The additional heat input may affect the temperature behavior.
- 09 Not in conjunction with the optional access port, door with window and interior lighting.
- 10 Not available on 23-liter units.
- 11 Not available on 23- or 53-liter units.
- 12 Only available on units rated for 230 V or 400 V.
- 13 Installation and connections take place at unit location; transport within the company only upon consultation.
- 14 We recommend a BINDER service contract to cover unit inspections, calibrations and validations.
- 15 OQ according to Yellow Paper = completed factory validation documentation of all OQ checklists.
- 16 Sensor calibration is performed in an accredited calibration laboratory.
- 17 Calibration is performed according to the BINDER factory standard.
- 18 Quoted prices do not include travel costs. Please refer to the chapter on BINDER Service for travel costs for your region. Quoted prices for services performed in Switzerland do not include a country-specific added fee (available on request).
- 19 For additional accessories, refer to the Process documentation chapter.

BINDER GmbH
 Tuttlingen, Germany
 TEL +49 7462 2005 0
 FAX +49 7462 2005 100
 info@binder-world.com
 www.binder-world.com

BINDER Asia Pacific (Hong Kong) Ltd.
 Kowloon, Hong Kong, P.R. China
 TEL +852 39070500
 FAX +852 39070507
 asia@binder-world.com
 www.binder-world.com

Representative Office for CIS
 Moscow, Russia
 TEL +7 495 988 15 16
 FAX +7 495 988 15 17
 russia@binder-world.com
 www.binder-world.ru



Helago-CZ s.r.o.
 Kladská 1082
 500 03 Hradec Králové
 Tel.: 495 220 229, 495 220 394
 Fax: 495 220 154
<http://www.helago-cz.cz>
 E-mail: info@helago-cz.cz

BINDER Environmental Testing
 Equipment (Shanghai) Co., Ltd.
 Shangha, P.R. China
 TEL +86 21 685 808 25
 FAX +86 21 685 808 29
 china@binder-world.com
 www.binder-world.com

BINDER Inc.
 Bohemia, NY, USA
 TEL +1 631 224 4340
 FAX +1 631 224 4354
 usa@binder-world.com
 www.binder-world.us